

HD 60K lbs Capacity Hydraulic Dock Leveler

Product Specifications

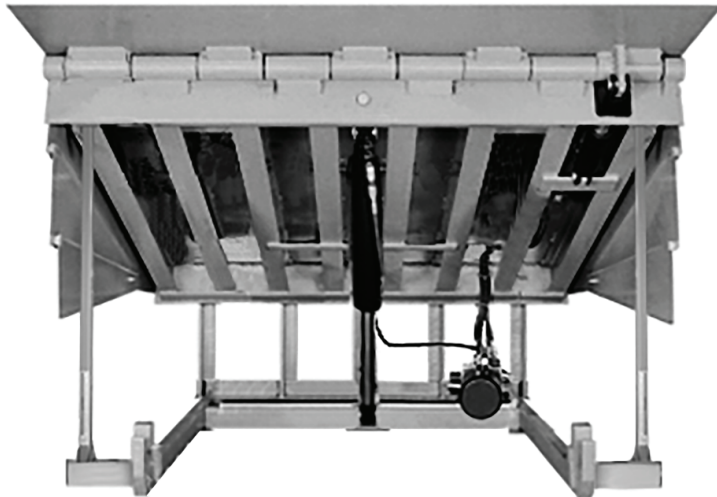

DESIGN HIGHLIGHTS

- Patented HYDRA MAX® powered-in/powered-out lip extension
- Regenerative hydraulics
- Yieldable hydraulic lip
- Non-metallic push-button control panel (non-interlock capable)
- Hydraulic velocity fuse safety stop
- CLEAN FRAME® design
- Full operating range toe guards
- Below-dock endloading capability
- 18" lip standard (457 mm)
- Grease fittings
- Dual integral maintenance struts & lip support latch
- 24" pit depth standard (610 mm)
- Heavy-duty B610-14F dock bumpers
- Reduced lip crown/extended lip chamfer

ACCESSORIES

- SL series restraint _____
- SLP recessed restraint
- MANUAL SURFACE CHOCK™ wheel restraint
- SURFACE CHOCK™ wheel restraint
- VERSACHOCK wheel restraint
- Universal Truck-Chock™ wheel restraint
- ALS light communication system
- MLS light communication system
- Digital master or combination control panel with HMI _____

AVAILABLE OPTIONS

- Steel NEMA 12 control panel (interlock capable)
- HDR model
 - Automatic return-to-dock
 - Steel NEMA 12 control panel (interlock capable)
- HDQ model
 - Mushroom-style stop button
 - Independent hydraulic lip control
 - Steel NEMA 12 control panel (interlock capable)
- HDQC model
 - Same features as model DHQ, plus:
 - Automatic return-to-dock
 - Weatherseal (brush or neoprene)
- Factory installed brush weatherseal
- Factory installed neoprene weatherseal
- ENERGY GUARD® perimeter weatherseal system
- Spray foam insulated deck
- Galvanized finish (deck, lip & subframe only)
- Special paint color
- 20" lip (508 mm)
- High lip crown
- Lip taper _____ (specify)
- Box option: For installation without pre-formed concrete pits, dock leveler supplied with integral pre-formed steel box for pour-in-place construction. Leveler shall be in an enclosed steel box structure complete with its own six-piece, welded structural curb angles and concrete anchors. The leveler is to be concreted in place as the floor is poured.
- Other _____

BUMPER OPTIONS

- B610-14 B610-14 steel faced
- VB620-11F Other _____

PROJECT INFORMATION

JOB NAME _____

ADDRESS _____

GENERAL CONTRACTOR _____

DISTRIBUTOR _____

MODEL _____ QUANTITY _____

VOLTAGE/PHASE _____

CERTIFIED FOR CONSTRUCTION

BY _____ DATE _____

COMPANY _____

ADDRESS _____

1. **General:** "HD" series hinged lip dock leveler with hydraulic operated platform and hydraulic lip extension and retraction. Unit conforms to ANSI MH14.1-1987 performance requirements. Unit to be manufactured by Serco.
2. **Construction, Platform Assembly:** Platform to be constructed of 3/8" (10 mm) minimum high tensile steel safety tread deck plate supported by I-beam construction. Structural members fully welded to front header.
3. **Lip Assembly:** Lip to be high tensile steel safety tread lip plate with a beveled leading edge. Lip to be solid 3/4" (19 mm) thick and 18" (457 mm) long. 7' (2.13 m) wide lip tapers to 6'-6" (2.01 m) at leading edge (6'-0" (1.83 m) taper optional). Lip hinge to have full width structural front header and heavy wall tubing with a minimum of 3/4" (19 mm) wall thickness. Hinge tubes to have gussets. Lip hinge shaft to be a minimum of 1 1/4" (31 mm) solid steel.
4. **Lip Extension:** Patented HYDRA MAX® lip extension mechanism utilizes a double acting cylinder to provide smooth powered lip activation. Lip is powered in both directions for easier operation, less maintenance and greater control.
5. **Rear Subframe and Hinge:** Rear structural frame consists of 5 vertically supported rear hinges.
6. **Power Unit:** Power unit is an electric hydraulic pump and valve assembly (can be remote mounted; required with shallow pits).
7. **Electrical:** Motor is 1 h.p., NEMA Standard T.E.N.V./56C frame. Standard motor voltages available are 120/208/240V single phase or 208/240V/480V and 575V three phase. RPM: 3450. Control panel has built-in motor overload protection as standard. Power unit is mounted to unit subframe (elevated off pit floor) and pre-wired to an integral junction box.
8. **Hydraulic:** Main cylinder minimum 3 1/2" (12 mm) diameter bore. Lip cylinder to be a minimum of 2 1/2" (63 mm) diameter bore. All weather hydraulic fluid with viscosity of 15 cSt at 40°C (100° F).
9. **Control Panel:** Standard: (Non-metallic, non-interlock capable, thermal overload, single push-button control panel.) Optional Single Button Control: Steel interlock capable single-button control panel with motor starter, thermal overload, control circuit breaker with reset capability. Single button activation. Optional Automatic Return-to-Dock capable. Interlocking with other dock equipment available for added safety. Optional Full Control: Steel interlock capable control panel with motor starter, thermal overload, control circuit breaker with reset capability. Separate control buttons shall be furnished for "LIP EXTEND", "RAISE", and "STOP" button as standard. Optional Mushroom-style Stop Button stops the leveler instantly when depressed at any time to enhance safety. The "STOP" button is a maintained contact type which activates a solenoid on the leveler hydraulic system. The dock attendant does not have to continuously hold the "STOP" button to maintain the leveler in a stop position. Optional Quick Cycle Lip Extend properly sized cylinder(s) and the "LIP EXTEND" button ensure quickest dock leveler cycle time by not having to fully raise the leveler before extending the lip onto the truck. Control panels are UL listed.
10. **Below-dock Control (Endloading):** Push-button controlled feature extends lip beyond lip supports to handle end loads. Optional Automatic Return-to-Dock capable. Interlocking with other dock equipment available for added safety.
11. **Product Finish:** Enamel gray finish.
12. **"Nite-Lock":** Permanent "Nite-Lock" to prevent unauthorized entry beneath locked overhead door is standard.
13. **Toe Guard Protection:** Full operating range toe guard protection is provided on the sides and rear of the leveler. Yellow OSHA required markings IAW ANSI Z535.1 provided on the sides of the dock leveler.
14. **Dual Integral Maintenance Struts:** Two permanently mounted, hinged, lockout capable maintenance struts and lip support latch are provided to support the lip section and leveler during maintenance.
15. **CLEAN FRAME®:** Unique design allows access for easy pit clean out and routine maintenance.
16. **Out of Level Compensation:** Rigid deck with a floating rear hinge.
17. **Float Compensation:** Allows for vertical carrier deflection when lip is in contact with truck bed.
18. **Operation:** Serco's "HD" Hydraulic Dock Leveler shall be supplied completely assembled with platform, lip, power unit, including motor, pump and valve assembly. "HD" unit to have hydraulic control of all functions. Platform and lip to be operated by hydraulic cylinders controlled by a remote push-button station. To operate dock leveler, dock attendant presses "RAISE" button, platform raises and lip extends hydraulically. When button is released, platform descends until lip is supported by the truck bed and floats with truck movement. To restore dock leveler, dock attendant presses "RAISE" button and lip retracts. If truck departs when lip is extended, leveler descends under hydraulic control and lip falls to pendant position. Optional Automatic Return-to-Dock (A.R.T.D.) feature automatically restores leveler to dock level support position. The Optional "LIP EXTEND" Button will extend the lip at any point in the dock leveler cycle. Pushing the Optional Mushroom-style "STOP" Button allows the attendant to stop the leveler immediately when necessary. Pulling out the button allows the leveler to operate again. Standard below-dock level operation allows for below-dock endloading with push-button control. Working range to be 12" (305 mm) above-dock and 12" (305 mm) below-dock for 6' (1.83 m), 8' (2.44 m) and 10' (3.05 m) long units and 15" (381 mm) above-dock and 12" (305 mm) below-dock for 12' (3.66 m) long units. The lip extends a minimum of 11" (279 mm) beyond the face of a 6" (150 mm) bumper.
19. **Installation:** Unit shipped completely assembled, and ready for installation in pre-formed concrete pit. Pit depth is 24" (610 mm) for all dock levelers. Pit construction to be in accordance with certified Serco pit detail drawings. Control panel is furnished for remote mounting and electrically interconnected by others. Contact Serco for current cost and nearest distributor.
20. **Limited Warranty:** Limited parts & labor warranty on all components under normal use for a 1-year "Base Warranty Period" beginning on the completion of installation or the sixtieth (60th) day after shipment, whichever is earlier. Additional limited 4-year parts only warranty on hydraulic power unit and cylinders. Limited prorated 10-year structural warranty available upon engineering approval of written application.
21. **Bumpers:** Unit to include two model B610-14F (6" Thick x 14" W x 10" H) (150 mm x 356 mm x 254 mm) heavy-duty bumpers.

NOMINAL DIMENSIONS		
MODEL	LEVELER WIDTH	LEVELER LENGTH
HD600	6' (1.83 m)	6' (1.83 m)
HD66.500	6'6" (2.01 m)	6' (1.83 m)
HD6700	7' (2.13 m)	6' (1.83 m)
HD800	6' (1.83 m)	8' (2.44 m)
HD86.500	6'6" (2.01 m)	8' (2.44 m)
HD8700	7' (2.13 m)	8' (2.44 m)
HD1000	6' (1.83 m)	10' (3.05 m)
HD106.500	6'6" (2.01 m)	10' (3.05 m)
HD10700	7' (2.13 m)	10' (3.05 m)
HD1200	6' (1.83 m)	12' (3.66m)
HD126.500	6'6" (2.01 m)	12' (3.66m)
HD12700	7' (2.13 m)	12' (3.66m)