

# SM Series Mechanical Edge-of-Dock Levelers

## Product Specifications



### DESIGN HIGHLIGHTS

- Exclusive lug style lip hinge provides superior strength and extended life
- High strength steel tread plate (ramp & lip)
- Reliable dual extension spring lifting mechanism
- Ergonomic design – easy operation that requires less lifting force
- Exclusive EZ-Lift™ spring assist on lip hinge reduces lifting force
- Heavy duty steel lifting handle with safety grip
- Operating range is 5" (127 mm) above to 5" (127 mm) below dock
- Effective working range is 3" (76.2 mm) above to 3" (76.2 mm) below dock
- Lower profile design reduces interference with material handling equipment
- Beveled lip edge (11 degrees) provides smooth interface with trailers
- 15" (381 mm) lip standard
- Tire laminated bumpers mounted to steel bumper blocks
- Exclusive EZ-Hang™ installation system simplifies install
- Integral maintenance/service strut

### AVAILABLE OPTIONS

- 17" (432 mm) lip for refrigerated trailers
- Post Office model with 2" (51 mm) cart guard
- Steel faced bumpers
- Tapered lip (tapered on each side)
- Recessed pit model
- Special surface finish
- Bumper projection 16", 17", or 18" (406, 432, or 457 mm) \_\_\_\_\_

### AVAILABLE ACCESSORIES

- Embed channel or transition model \_\_\_\_\_
- Vehicle restraint-model \_\_\_\_\_
- Dock seal or shelter-model \_\_\_\_\_
- Other \_\_\_\_\_

### PROJECT INFORMATION

JOB NAME \_\_\_\_\_

ADDRESS \_\_\_\_\_

GENERAL CONTRACTOR \_\_\_\_\_

DISTRIBUTOR \_\_\_\_\_

MODEL \_\_\_\_\_ QUANTITY \_\_\_\_\_

### CERTIFIED FOR CONSTRUCTION

BY \_\_\_\_\_

COMPANY \_\_\_\_\_

ADDRESS \_\_\_\_\_

DATE \_\_\_\_\_

- General:** Unit meets or exceeds MH14.1-1987 performance requirements.
- Construction:** Deck and lip to be 3/8" (9.52 mm) to 1/2" (12.7 mm) thick (depending upon capacity) high tensile steel tread plate. Conforms to ANSI/MH14.1 1987 performance requirements. Self-cleaning lug-style front lip hinge with heavy-duty lugs robotically welded to ramp assembly. Ramp assembly projects 13" (330 mm) from dock in the stored position and the standard lip length is 15" (381 mm). Dual extension spring lift mechanism offers reliability and ease of operation and operating handle is 1 5/8" (33.3 mm) diameter steel pipe.
- Bumpers:** Unit to include two 4"x10"x12" (101 mm x 254 mm x 305 mm) tire laminated bumpers mounted to steel block assemblies. Bumper projections available in 16", 17" and 18" (406, 432 & 457 mm). See chart for bumper projections.
- Working Range:** Operating range is 5" (127 mm) above to 5" (127 mm) below dock level. Effective working range is 3" (76.2 mm) above and 3" (76.2 mm) below dock level\*
- Operation:** Simple pull of the activation handle raises the ramp into position. Attendant easily pushes the handle forward to extend the lip into the trailer. The unit can be stored by again pulling the handle to remove the lip from the trailer.
- Installation:** Unit ships completely assembled for easy installation. Unit to be securely welded to a channel (8" (203 mm) minimum) embedded in concrete and secured with anchoring hooks as recommended. Instructions are defined in the product's Owner's Manual.
- Limited Warranty:** Warranted against defects in materials and workmanship for one year.

\* Due to the limited length of EOD levelers, its structure is subjected to greater dynamic load than with longer levelers. Capacity selection is based on ideal operating conditions (i.e. maximum gross load traveling at 3 mph on 10% grade or less); if the application exceeds this condition a higher capacity leveler must be selected.

NOMINAL DIMENSIONS			
MODEL	WIDTH	LENGTH	CAPACITY
SM6620	66" (1676 mm)	27" (686 mm)	20,000 lbs. (9091 Kg)
SM6630	66" (1676 mm)	27" (686 mm)	30,000 lbs. (13,636 Kg)
SM7220	72" (1829 mm)	27" (686 mm)	20,000 lbs. (9091 Kg)
SM7230	72" (1829 mm)	27" (686 mm)	30,000 lbs. (13,636 Kg)
SM7830	78" (1981mm)	27" (686 mm)	30,000 lbs. (13,636 Kg)
SM8430	84" (2134 mm)	27" (686 mm)	30,000 lbs. (13,636 Kg)

BUMPER PROJECTIONS		
LIP LENGTH	CROWN	PROJECTION
15" (381 mm)	5°	16" (406 mm)
15" (381 mm)	8°	16" (406 mm)
17" (432 mm)	2.5°	18" (457 mm)
17" (432 mm)	5°	17" (432 mm)
17" (432 mm)	8°	16" (406 mm)

### Channel and Anchor Detail

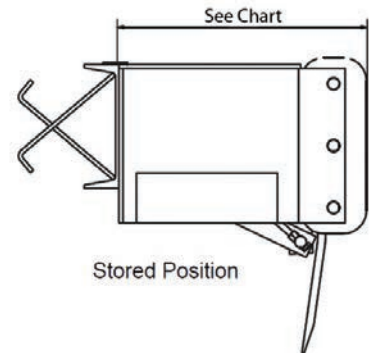
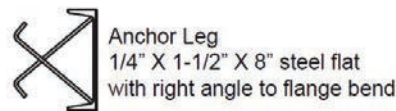
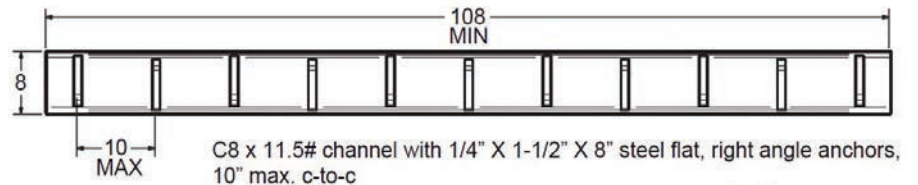

A	B
66"	98"
72"	104"
78"	110"
84"	116"

