

HED Series Hydraulic Edge-of-Dock Leveler Specification Sheet and Submittal



STANDARD FEATURES FOR THE HED EDGE-OF-DOCK LEVELER

- NEMA 4 Push Button Control Panel
- Cold-rolled Steel Hinge Pins for Added Strength and Long Life
- Grease Fittings
- High-strength Steel Safety Tread Plate, Minimum 55,000 PSI Yield Strength
- Fully hydraulic lip & deck cylinders
- Milled Lip Edge for Smooth Tire Rollover
- 66", 72", 78", and 84" deck width
104", 110", 116", and 122" total widths
- Fully Hydraulic Lip & Deck Cylinders
- Secondary Gussets for added strength & Extended Life
- Heavy Duty Bumper Block Assemblies with "Tuf-Cord"™ 4"x12"x13" Rubber Bumpers
- Bumper Projection = 18"

HED Series Hydraulic Edge-of-Dock Leveler Specification Sheet and Submittal

GENERAL: DLM invented the industries first "edge-of-dock" leveler over 40 years ago, setting the pace for the industry. The DLM "HED" series hydraulic Edge-of-Dock Leveler mounts to the exterior dock face providing a simple and economical alternative to "portable plates" or "pit style" levelers. Edge-of-Dock Levelers are ideal for the motor freight industry or those companies with standardized trailer bed heights. DLM is a division of Systems, LLC in Germantown Wisconsin.

CONSTRUCTION: The platform and lip are constructed of 4-way high tensile 55,000 psi minimum yield A572 safety tread plate. The tread plate on the 20,000 and 25,000 lbs CIR units is 3/8" thick, the 30,000 lbs CIR unit is 7/16" thick and the 35,000 lbs CIR unit is 1/2" thick. The standard lip length is 15" on all HED Series edge of dock levelers. Hinge tubes are 1 1/4" OD for 20,000, 25,000 and 30,000 lbs CIR and 1 1/2" OD for 35,000 lbs CIR units. Lip hinge pins are 11/16" solid shaft cold finish M1044 steel for 20,000, 25,000 and 30,000 lbs units and 1" FOR 35,000 lbs CIR units. Each edge of dock leveler comes standard with 1/2" full width load distribution bar, meeting the hinge and lip sections. Deck is supported in the stored position by a minimum of two (2) steel gussets attached to the base plate.

HYDRAULICS: Platform is raised by a main hydraulic cylinder; all hydraulic hoses are safely routed under the HED platform. Lip operation is controlled by a second independent lip cylinder. Motor pump is mounted under HED on brackets for easy access. Reservoir is translucent for monitoring of fluid level.

STANDARD OPERATIONAL FEATURES: The HED is controlled remotely from a wall mounted control panel. The platform is raised when the raise push button on the control panel is depressed and held. When the fully yieldable lip extends the button is released allowing the extended lip and platform to lower onto the trailer bed at either above or below dock position. Upon trailer departure the lip automatically restores itself to the stored position. The unit can also be restored with the trailer at the dock. In-use and store positions are achieved without manual operation. Each HED Series model provides a recommended working range of +/-3" and a maximum operating range of +/-5" above or below dock level. Standard lip is 15". (17" lip available for refrigerated trailers) The HED deck and lip move up and down under hydraulic pressure.

BUMPER BLOCK ASSEMBLIES: Each HED Series Leveler is shipped with two (2) bumper block assemblies to help protect the deck plate and building from the approaching truck. Bumper block assemblies are

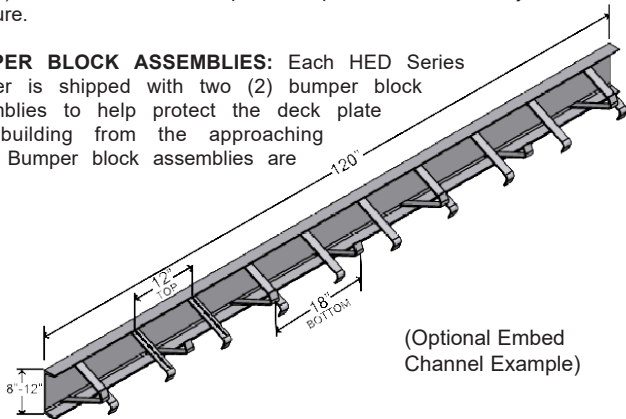

extra-heavy duty 4"x12"x13" constructed of formed steel and incorporate a full height internal gusset for extra support. All DLM bumper blocks feature 4" thick Tuf-Cord rubber bumper.

ELECTRICAL: Hydraulic pump motor either 1 HP TENV at 115v or 230v, single phase or at 208v, 230v or 460v three phase. All electrical components, connections and wiring are UL listed or recognized. **Please Note: Unless specifically noted on quotation, all electrical requirements are the responsibility of others.**

INSTALLATION: For new construction a flush or recessed 8" to 12" anchoring channel is strongly recommended. Unit is welded and anchored to embed plate and foundation wall. For existing docks without preferred embed channel optional ramp approach plates or formed angles are available to maximize the strength of the installation.

WARRANTY: All DLM HED Series Hydraulic edge-of-docks feature a full one (1) year base warranty on all structural, hydraulic and electrical parts, including freight and labor charges in accordance with Systems, LLC's Standard Warranty Policy. Systems, LLC warrants all components to be free of defects in materials and workmanship, under normal use, during the warranty period. This base warranty period begins upon the completion of installation or the sixtieth (60th) day after shipment, whichever is earlier.

Dimensions and Capacities <small>Select a Model and a Capacity</small>			
Model #	Deck Width	Total Unit Width	Comparative Industry Rating
<input type="checkbox"/> HED-66	66"	104"	<input type="checkbox"/> 20,000
<input type="checkbox"/> HED-72	72"	110"	<input type="checkbox"/> 25,000
<input type="checkbox"/> HED-78	78"	116"	<input type="checkbox"/> 30,000
<input type="checkbox"/> HED-84	84"	122"	<input type="checkbox"/> 35,000

Optional Equipment for Edge-of-Dock <small>(Check options desired)</small>	
<input type="checkbox"/> 17" Lip <input type="checkbox"/> Tapered Lip (4" < ramp width) <input type="checkbox"/> U.S. Post Office Model with 3" Run Off Guards <input type="checkbox"/> Recessed Design with 4" Thick Laminated Bumpers <input type="checkbox"/> Sliding Bumper Blocks <input type="checkbox"/> Other Bumpers <input type="checkbox"/> Low Clearance Design (Flat Center Plate) Pallet-Jack Applications <input type="checkbox"/> Four Sided Box Form <input type="checkbox"/> Embed Channel Size _____	<input type="checkbox"/> Approach Plate Size _____ <input type="checkbox"/> Formed Angle Size _____ <input type="checkbox"/> iDock™ Alert Communication System <input type="checkbox"/> Dock Alert Communication System <input type="checkbox"/> TPR® Restraint <input type="checkbox"/> PowerStop® Restraint (automatic) <input type="checkbox"/> PowerStop® Restraint (manual) <input type="checkbox"/> Wheel Chock Model _____ <input type="checkbox"/> Dock Light Model _____

Customer: _____ Job: _____ Location: _____ Number of Units: _____ Model: _____ Size: _____ Represented By: _____ SalesRep: _____	Certified For Construction: By: _____ Date: _____ Company: _____ City & State: _____ Voltage/Phase: _____ Drawing #: _____
---	---