



Hydraulic Loading Dock Levelers

Conventional and Roll-Off Stop Lip



With over 30 years of experience manufacturing quality loading dock equipment, Pentalift is your single-source supplier for loading dock levelers, dock lifts, dock seals & shelters, vehicle restraints, and much more.

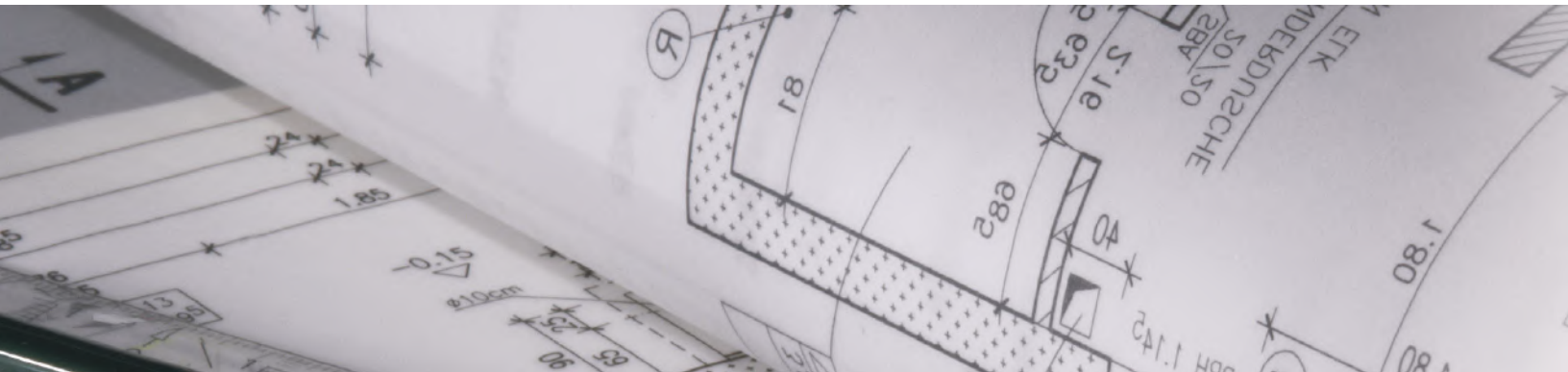

Engineered for Safety

Pentalift Company Information



Since 1983 Pentalift has grown to be recognized as one of North America's premier manufacturers of Loading Dock and Dock Lift Equipment. The simple business philosophy of manufacturing a quality product with user safety in mind continues to be our approach in the marketplace. Pentalift's continuing success in designing, engineering, and manufacturing loading dock solutions has gained Pentalift an excellent reputation within the materials handling industry.



Pentalift has a team of industry experts with extensive experience that stands ready to assist you with your most complicated applications.

Pentalift Dock Design Information

Pentalift has developed a comprehensive loading dock design guide that can be found on our website www.pentalift.com/safety-resources.php. Careful consideration should be given to all aspects when designing an efficient and safe loading dock. Below are some aspects of loading dock design to consider.

Type of Dock Leveler:

- LODEM is an industry group within MHI - The Material Handling Institute. The Loading Dock Equipment Manufacturers (LODEM) members are the industry's leading suppliers of loading dock equipment. They supply solutions worldwide and in virtually every major manufacturing and distribution sector.
- In the document created in this group titled **WHAT YOU ALWAYS WANTED TO KNOW ABOUT DOCK LEVELERS**, on page 7 states: **"The hydraulic option gives you more versatility than either mechanical or air dock levelers and typically would have lower service and maintenance costs."** Hydraulic are preferred over mechanical and air activated dock levelers.

Width of Dock Leveler:

- There are three common widths 6' wide, 6.5' wide and 7' wide, nominal
- 7' wide provides the best access for loading / unloading side-by-side pallets

Length of Dock Leveler:

- There are three common lengths 6' long, 8' long and 10' long, nominal
- 8' long is most popular

Dock Leveler Capacity:

- Available in 25-30-35-40-45-50-60-80 and 100,000 lb capacity
- Specifying a capacity higher than the calculated requirements will extend the life expectancy of the dock leveler
- See link to understanding loading dock capacity here: www.pentalift.com/loading-docks/capacity.php

Lip Length:

- There are 3 standard size dock leveler lips 16", 18" and 20"
- Ideally you want to have a lip that is 12" beyond the dock bumpers
- 16" lip length is standard with a 4" dock bumper

Other factors that may influence dock leveler selection:

- Door size
- Dock height
- Dock bumpers
- Driveway approach: level, incline, or decline

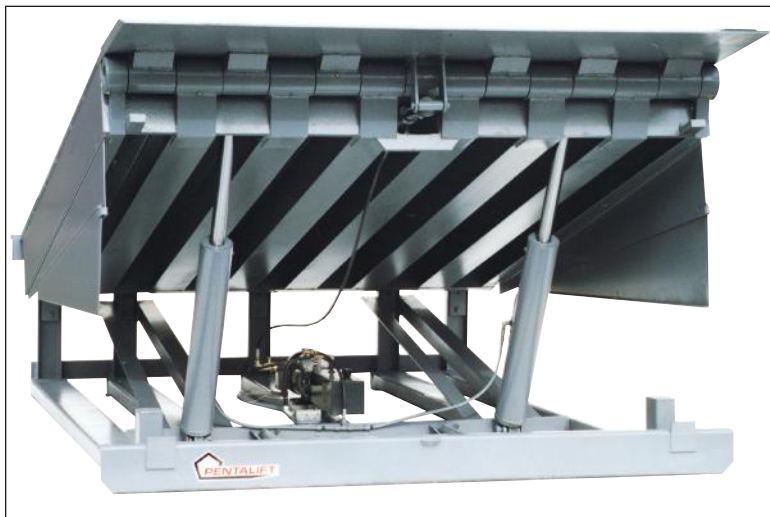

Pentalift manufactures dock levelers to suit every application from a 25,000 lb capacity mechanical to this 160,000 lb capacity hydraulic dock leveler

Featuring:

- 1/2" thick deck plate
- 1-1/2" thick lip plate
- 1" thick by 10" high headboard
- 10" deep deck beams
- 2-1/4" diameter lip hinge pin
- 4-1/2" diameter, gusseted hinge spools
- Dual hydraulic lift cylinders

Pentalift Series HD Hydraulic Dock Leveler

The Pentalift series HD hydraulic dock leveler offers many beneficial operational and safety features. These features are shown on the following pages.

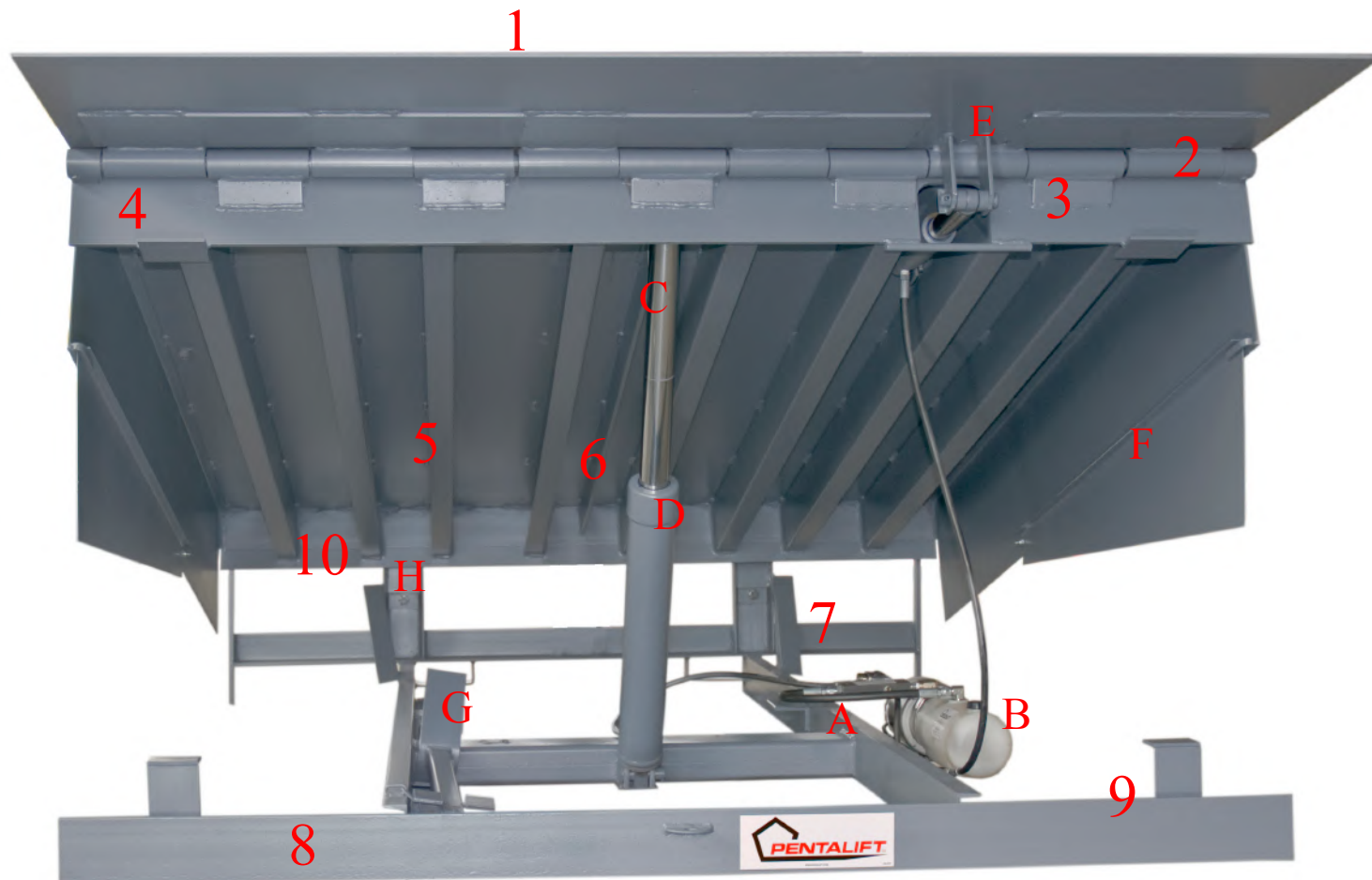

Model HD6835 shown

Series HD Hydraulic Dock Leveler Structural Features

- 1 High-strength, 4-way safety tread plate, deck and lip assembly: 55,000 psi yield.
- 2 Full-width self cleaning, heavy-wall hinge tube: 70,000 psi yield.
- 3 Gussets on lip and headboard hinge maximize support.
- 4 3/8" Thick, 50,000 psi yield, headboard with bridged gaps.
- 5 Structural, precision-formed "C" beams; 65,000 psi yield. Specially designed beams allow Pentalift to create and build the deck support with optimal strength-to-weight ratio for a dock leveler. Utilizing 10 beams assures an even load distribution and maximum deck support.
- 6 Central deck beam for added support of three wheeled vehicles.
- 7 Rear frame assembly features four vertical structural members with six points of even support for the full width of the rear hinge.
- 8 Heavy-duty front frame provides full width, cross traffic support and superior building aesthetics.
- 9 Night locks prevents unauthorized entry when overhead door is locked on top of dock leveler.
- 10 Full width, structural channel tail board and one piece, full width rear hinge, complete with heavy steel gussets. Pentalift's unique, welded assembly provides a box section for superior support and strength.

Pentalift Series HU Ultima Hydraulic Dock Leveler

The Pentalift series HU Ultima hydraulic dock leveler provides the ultimate value in function and structure available in a dock leveler.

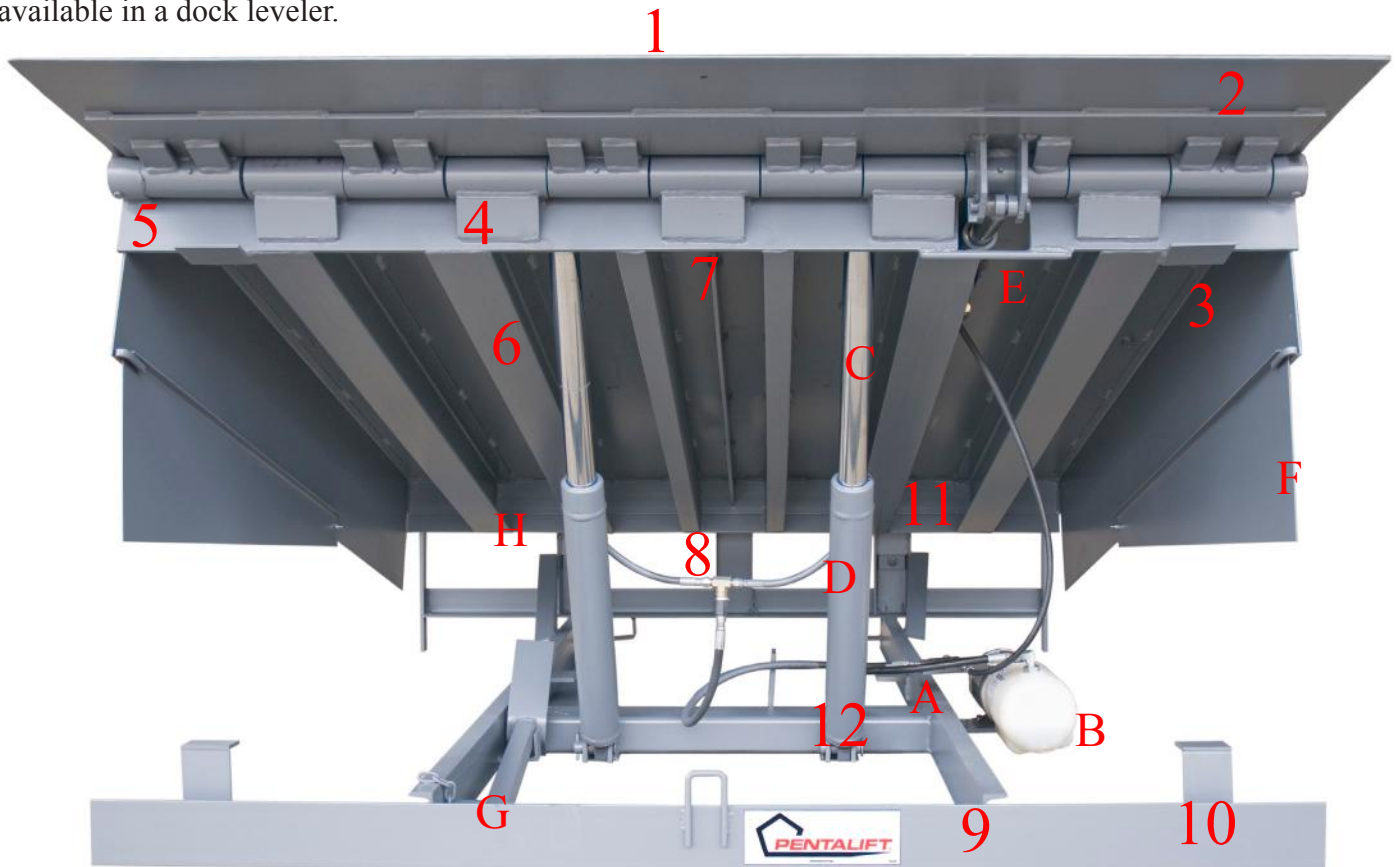

Model HU6845 shown

Series HU Ultima Hydraulic Dock Leveler Structural Features (45,000 lbs capacity)

1. Deck plate high-strength, 4-way safety tread plate, deck and lip assembly: 55,000 psi yield.
2. Lip plate assembly high-strength safety checker plate lip assembly. 1" rear laminated; c/w 3/8" x 6" reinforcing plate, 55,000 psi yield.
3. Full-width self cleaning, heavy-wall hinge tube, 2-1/2" OD X 1-1/2" ID: 70,000 psi yield.
4. 3/8" thick gussets on lip and headboard hinge maximize support.
5. 3/8" Thick, 50,000 psi yield, headboard with bridged gaps.
6. **"I" Beam deck support 6" structural "I" beams @ 12 lbs per foot.**
7. Central deck beam for added support of three wheeled vehicles.
8. Rear frame assembly features five vertical structural members with eight points of even support for the full width of the rear hinge.
9. Heavy-duty front frame provides full width, cross traffic support and superior building aesthetics.
10. Night locks prevents unauthorized entry when overhead door is locked on top of dock leveler.
11. Full width, structural channel tail board and one piece, full width rear hinge, complete with heavy steel gussets. Pentalift's unique, welded assembly provides a box section for superior support and strength.
12. Dual deck lift cylinders.

Pentalift Series HDRS Roll-Off Stop Hydraulic Dock Leveler

Roll-Off Stop feature further enhances safety at the loading dock

Pentalift's Series "HDRS" Roll-Off Stop lip hydraulic dock levelers feature all of the design, structural and operational benefits of the HD and HU Series Pentalift hydraulic dock levelers shown in this brochure, with the added safety enhancement of a Roll-Off Stop lip. The Roll-Off Stop dock leveler is available in either the HD or HU Series dock leveler configurations.

The Roll-Off Stop lip is a formidable barrier. It prevents lift truck roll-off from the loading dock, whenever the dock leveler is in the parked positioned.

The Roll-Off Stop lip also serves to protect roll-up doors on truck trailers positioned at the loading dock from impact and damage.



Roll-Off Stop Dock Leveler Lip Features



The Pentalift Series HDRS Roll-Off Stop dock leveler offers the following headboard and hinge features:

8" High Roll-Off barrier stop: The Pentalift barrier is one of the highest in the industry. This increases the stopping presence of the dock leveler and further enhances loading dock safety.

Structural tubing headboard / hinge: The structural tubing headboard, heavy duty gussets and hinge construction of the Pentalift Series HDRS dock leveler provides an extremely strong headboard section at the front of the dock leveler. This headboard section will withstand substantial impacts if the Roll-Off Stop feature is put to use. It also results in an improved and stronger headboard and lip hinge arrangement for normal dock leveler loading and unloading.

Pentalift's offset hinge design automatically provides a barrier when the lip is parked in the vertical position.

The full width, self cleaning, piano-style hinge ensures ongoing, reliable performance with low maintenance. The raised lip design spreads the load on the hinge area over a larger area and with better leverage, making this lip design stronger than the conventional lip designs.

By eliminating intricate sliding mechanisms Pentalift's Series "HDRS" levelers maintain the roll-off stop feature at all times, even during higher risk, below level, end-loading operations.



Pentalift Series HD,HU&RS Hydraulic Dock Leveler Operating Features

Pentalift hydraulic dock levelers incorporate unique and important operating features to achieve the most safe and reliable operation available in a hydraulic dock leveler. These operating features are described in more detail below.

A Pentalogic™ Hydraulic Control Manifold

Operating every hydraulic function with only two moving parts, the Pentalogic hydraulic control manifold revolutionized dock leveler hydraulic control circuitry. Conventional hydraulic dock leveler control valve circuitry is comprised of several individual function valve assemblies. Their assemblies are constructed from many sub components, increasing the potential of hydraulic component failure and oil leaks. Utilizing only two moving components, the non-adjustable Pentalogic hydraulic manifold eliminates all concerns related to on-site adjustment, oil leaks or hydraulic component failure.



B Hydraulic Power Unit



Incorporates internal filtration system and 1-1/2 HP Totally Enclosed Non Ventilated motor. Provides hydraulic flow and pressure to the Pentalogic hydraulic manifold. Simple and reliable even in the harshest applications. Hydraulic power units are available in all common single and three phase AC voltages.

C Lift Cylinder Placement (See next page 8 for more details)

The beneficial advantage of the Pentalift lift cylinder placement is explained in more detail on page 8.

D Top-Fed Forward Positioned Lift Cylinder

Top feeding the hydraulic cylinder automatically ejects air from the hydraulic system. It also maintains the hydraulic connection and hoses away from dirt and debris on the pit floor.

E Self Retracting Hydraulic Lip

Pentalogic hydraulic manifold allows the lip assembly to gently retract into the pendant position prior to the arrival of the next incoming vehicle. An illustration and more detailed explanation is provided on page 8.

F Full Range Toe Protection

Full range telescopic toe protection; upper and lower sections feature a "bend relief" to increase strength.

G Integral Maintenance Stand (See page 4 for photo in dock leveler & shown in stored position)

Integral maintenance stand facilitates support during routine support and maintenance. Pentalift maintenance stand supports the lip as well the dock leveler deck assembly.

H Fixed Rear Hinge

Fixed rear hinge remains flush with the rear of the pit to eliminate pinch points and surface obstructions. Small gap at deck plate and frame conjunction reduces impact or bump for fork lift operator compared to competitive designs.

Lift Cylinder Placement: Pentalift vs Other Manufacturers

Other Manufacturers:

Other manufacturers position their lift cylinders as illustrated below. During a fallsafe condition, with the front tire of the forklift past the upper cylinder support point, a dangerous "teeter-totter" situation occurs. The back of the deck is forced upwards and out of the rear frame. In addition, the positioning creates a mechanical disadvantage during fallsafe (1" stroke = 4" deck drop). Other cylinders with the chrome plated piston facing downward are prone to surface damage and chipping leading to hydraulic seal failure.



Pentalift:

For most effective support, Pentalift's lift cylinder is securely positioned at the junction of the deck and the structural headboard. The base of the cylinder is connected to a structural cross member. During a hydraulic fallsafe situation the fork lift will be completely supported between the cylinder position and the rear frame. All generated forces are downward, in the direction that all dock levelers are designed to accept load forces. The Pentalift lift cylinder is positioned correctly away from debris found in the pit. It's position provides a superior mechanical advantage.



Self-Retracting Lip: Pentalift vs Other Manufacturers

Other Manufacturers:

Conventional hydraulic dock levelers, yieldable lip circuits utilize an "in line" pressure relief valve, maintaining the lip in the extended position. Once a vehicle departs, the deck lowers with the lip in the extended position. The next incoming vehicle will impact the extended lip and any excessive force will push the lip assembly back into the pendant position. In addition, a conventional hydraulic circuit can cause the lip to get "caught on" a portion of the incoming truck, resulting in extensive damage to the vehicle, dock leveler and cargo.

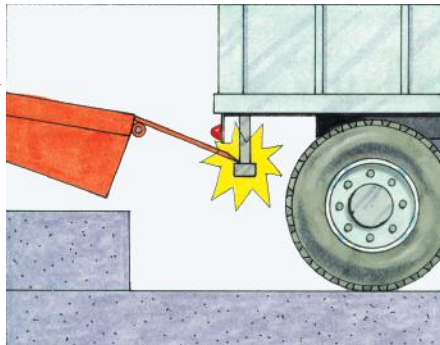

Pentalift:

On truck departure, the Pentalogic hydraulic manifold allows the lip assembly to gently retract into the pendant position prior to the arrival of the next incoming vehicle. The Pentalogic hydraulic manifold assures that the lip is always pendant behind the protective bumpers. Units equipped with automatic return-to-stored-position, work in conjunction with the self-retracting lip (eliminating false signals common with other manufacturers), to return the deck to the safe stored position.

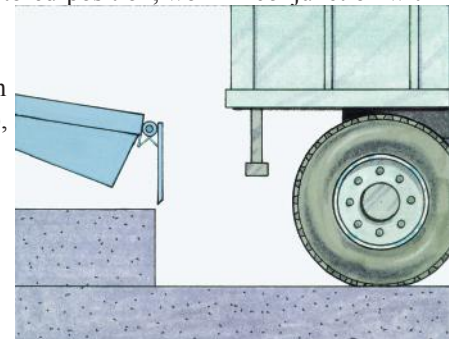

Pentalift Hydraulic Dock Leveler Control Panels

Pentalift adds value by designing and assembling its own control panels, "in house" at the factory to accommodate the interlocking of other dock equipment such as vehicle restraints, overhead doors and inflatable dock seals/shelters to create a safe and productive loading dock system. Please contact your Pentalift representative for options available for your application.



Simple Basic Operation

- NEMA 12 – wall mounted push button station, facilitates simple basic operation.
- Protects against falling dirt, circulating dust, lint, fibers, filings and against dripping and light splashing of liquids.
- Other NEMA rated enclosures are available.

Optional Auto Return, Deck Stop with Independent Lip Control Features

Auto Return:

- This feature allows the leveler to automatically reposition itself back to the stored position.
- If a truck leaves the dock before the leveler is stored by the attendant the leveler will slowly travel to the bottom of the pit and then automatically re-store itself.
- Included is a selector switch that enables the dock attendant to turn off the auto return feature during below dock end loading / unloading operations.

Deck Stop with Independent Lip Control

- The Deck Stop feature adds the ability for the operator to fully stop the travel of the leveler deck while in operation, all with one button. This enhances the operation and assists with protecting product loaded at the end of the trailer.
- The Independent Lip Control feature allows the dock attendant to have full and complete control of the dock leveler lip extension throughout the operating range of the leveler. It allows easier positioning of the lip for end loading / unloading operations.



Master Control Panels

- Proven long term technology eliminates replacing costly touch pad circuit boards. Hard wired components are more robust than circuit board designs. This is important in loading dock environments in which dramatic temperature change typically take place. Hard wired components are easier for the average electrician to trouble shoot and result in lower maintenance costs. Operator confusion or error is addressed by providing a single interlocked and synchronized panel to operate all equipment at the loading dock. Master control panels provide a productive and safe operating dock system and the single panel significantly reduces electrical hook-up costs.



Other Control Panel Options:

- Lockable electrical disconnects
- Overhead door controls
- GFCI duplex outlets for dock light
- Other NEMA rated enclosures
- For special requests consult factory

Pentalift Hydraulic Dock Leveler Options

Pour In Place



This option simplifies installation and reduces costs in new construction applications. A metal frame and pan encloses the dock leveler. This allows the dock leveler to be placed into a recess in the foundation and to have concrete poured around it during the floor pour of the building. Installation welding is completed at the factory. Overall costs of installing the dock leveler are reduced substantially. See www.pentalift.com/safety-resources.php. Pentalift Loading Dock Design Guide pg. 20 for more details.

Weatherseal



This option provides a rubber or brush weatherseal along the sides and rear of the dock leveler. The weatherseal reduces the passing of outside elements (cold, heat or debris) from outside into the facility by sealing the edges of the dock leveler against the dock leveler pit. In addition, brush weatherseal is effective in reducing the entry of vermin into the facility as well. The weatherseal is provided with metal carriers. As wear results to the seal, replacement seals can be simply slid into the metal carriers.

Steel Face Dock Bumpers



This option provides a very durable dock bumper. The bumper is comprised of laminated bumper sections behind a plate steel bumper face. The laminated rubber sections absorb the impact of the truck and trailer as it backs into the facility. The steel facing prevents the trailer from cutting or overly compressing the rubber absorption material as the trailer backs into the loading dock and scrapes up and down on the bumpers as it raises and lowers with the suspension. The combination of the two components makes the steel face dock bumper an excellent solution for harsh loading dock environments.

Other available options for Hydraulic Dock levelers

Longer Lip Lengths

Hot Dip Galvanized or Epoxy Paint Finishes

Weatherseal Rubber or Brush (shown above)

Shim Kits (To fit dock leveler to deeper pits)

Upgraded Capacities

Pour In Place Installation (shown above)

Spray Foam Insulation

Easy Sweep Frame

Safety at the Loading Dock

The loading dock has been rated as one of the most hazardous areas of any facility. To increase safety at the loading dock more and more companies are installing a combination of hydraulic dock levelers and vehicle restraints.

Pentalift vehicle restraints not only lock the trailer in position, they also provide clear communications between the truck driver and the loading dock attendants.

Pentalift Vehicle Restraint Systems

Pentalift manufactures and offers four styles of vehicle restraints. The variety of designs provided suit almost any loading dock application and create a safe productive loading dock system. All units can be interlocked to the dock leveler for increased safety. Contact a Pentalift sales representative for additional information.



Model RVR32:

A raised, face mounted, off the ground design. The front extension bar provides an operating range of 9” low to 25” high.



Model HFR32:

Reliable hydraulic operation is controlled by push buttons. Suitable for harsh, busy environments.



Model LPR35:

Provides the same features and benefits of the HFR32. In addition features an extremely low lowered height as well as a stepped hook for dual locking positions.



Model UHR40:

Installed under the dock leveler to provide the ultimate in safety, performance and reliability. Suitable for severe and extremely busy environments.

Pentalift also provides a wide variety of equipment to create an efficient, secure, and safe loading dock environment. In addition to the products shown in the photographs below Pentalift also offers the following products; including edge of dock levelers, safety barriers, wheel chocks, dock lights, and dock bumpers, making Pentalift your ideal, single-source, loading dock equipment supplier.

Pentalift Mechanical Dock Levelers



Pentalift Vehicle Restraints (See page 11)

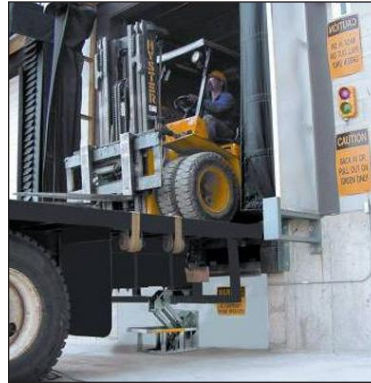

Pentalift Dock Seals and Shelters



Pentalift Vertical Storing Dock Levelers



Pentalift Dock Lifts



Pentalift Truck Levelers & Dock Seals



"Our Primary Goal is to engineer and build the best products to ensure the ultimate in user safety and product reliability"

*Paul Pedersen
President
Pentalift Equipment Corporation*

Individual Product Catalogs are available and can also be found on our website.
Pentalift also manufactures a complete line of lift tables for your in plant material handling needs.

Note: Some photos may reflect products with optional features. All Pentalift Equipment Corporation products are subject to design improvement through modification without notice.